

## 0-10V Dimmer

E610P-RF



Manual

[www.ltech-led.com](http://www.ltech-led.com)

## System Diagram

### L-BUS

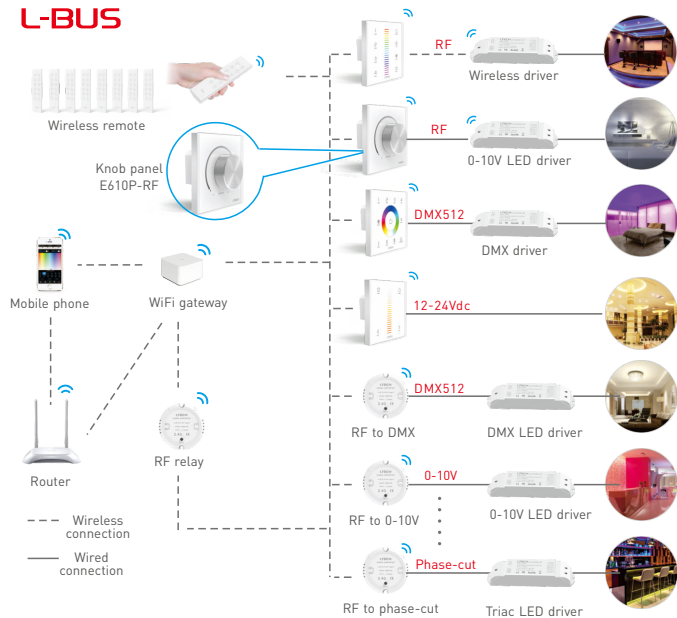

## Product Features

LTECH

- Adopt wireless RF and wired 0-10V 2 in 1 control mode, more flexible and convenient for project installation.
- With the function of dimming and switching.
- The panel can be controlled by remote, or by mobile phone if add a gateway.

## Technical Specs

E610P-RF 0-10V dimmer

Input Voltage:	100~240Vac, 50-60Hz	Working Temp.:	-10°C~35°C
Switching Power:	90~250Vac, 5A	Dimensions:	L86×W86×H50(mm)
Output:	0~10V Max. 50mA	Package Size:	L106×W106×H60(mm)
Wireless Signal:	RF 2.4GHz	Weight(G.W.):	220g
Anti surge:	≤100A / 10msec		

CE RoHS

[warranty  
5 years]



## Installation Instruction

LTECH

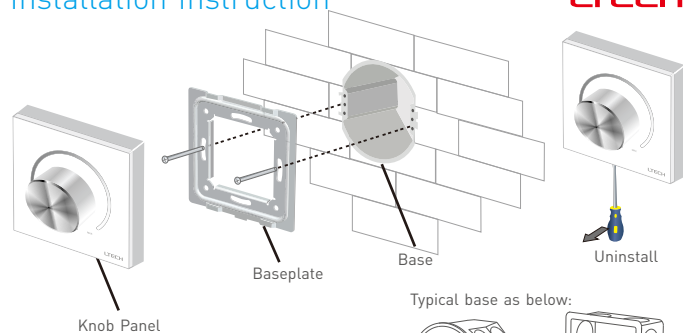

Typical base as below:

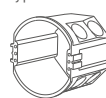

European style

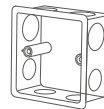

86 size

## Product Size

Unit: mm

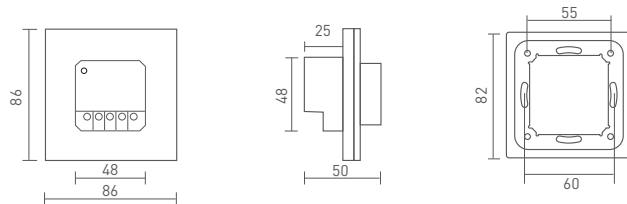

## Key Functions

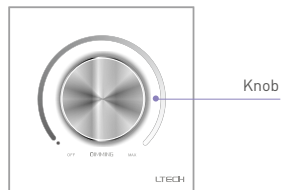

- \* Clockwise spin the knob, the brightness increases.
- \* Counterclockwise spin the knob, the brightness decreases. Turn off the panel if you spin to the leftmost end (a click can be heard).

## Terminals LTECH

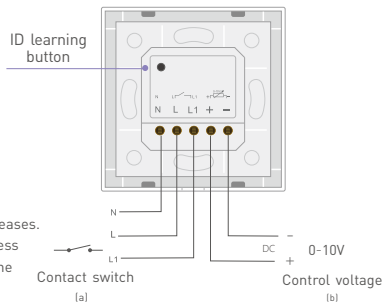

## Application Composition

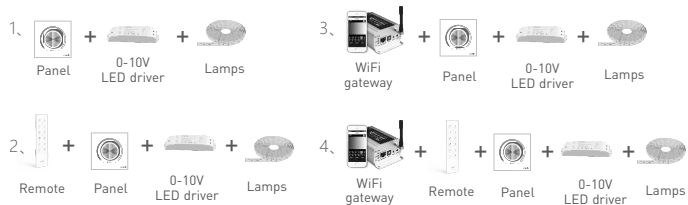

## Wiring Diagram

### 1. Dimming

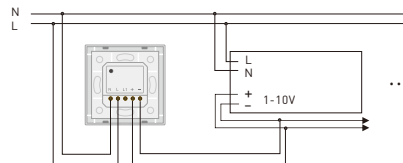

### 2. Built-in power switch

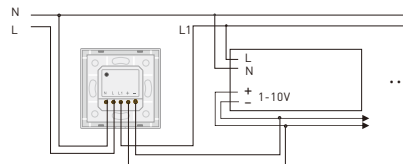

### 3. External relay connection

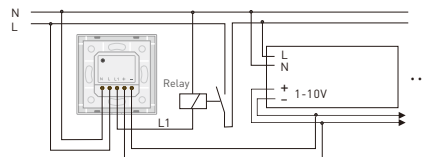

## Match Code between Panel & Remote **LTECH**

1. Short press "ID learning button" on E610P-RF, the lamps flicker.

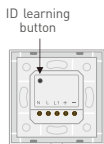

2. Hold down On/Off key on F1, or hold down the matching zone's On & Off keys on F5 simultaneously, if the lamp flicker quickly then back to normal, match successfully.



- \* Exit match status automatically if over 15 seconds.
- \* One E610P-RF can be matched with max 10 remotes.

## Match Code between Panel & WiFi-106

1. Turn on APP, click "ZONE" key to enter "zone set" interface.



2. Click the right top "MATCH" key, then operate following the prompts.



## Clear Code

Long press "ID learning button" on E610P-RF for 10s until the lamps flicker 5 times, clear code successfully.

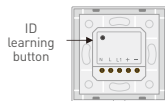

## Warranty Agreement

**LTECH**

1. We provide lifelong technical assistance with this product:
    - A 5-year warranty is given from the date of purchase. The warranty is for free repair or replacement if cover manufacturing faults only.
    - For faults beyond the 5-year warranty, we reserve the right to charge for time and parts.
  2. Warranty exclusions below:
    - Any man-made damages caused from improper operation, or connecting to excess voltage and overloading.
    - The product appears to have excessive physical damage.
    - Damage due to natural disasters and force majeure.
    - Warranty label, fragile label and unique barcode label have been damaged.
    - The product has been replaced by a brand new product.
  3. Repair or replacement as provided under this warranty is the exclusive remedy to the customer. LTECH shall not be liable for any incidental or consequential damages for breach of any stipulation in this warranty.
  4. Any amendment or adjustment to this warranty must be approved in writing by LTECH only.
- \* No further notice if any changes in the manual. Product function depends on the goods. Please feel free to contact our official distributor if any question.